



System 75 - Antistatic (AS)

Extraction arms

Table mounting	75 AS 2
Wall and ceiling mounting	75 AS 3

Hoods

Suction pen 1-7525-6	75 AS 4
Metal hood 1-7524-6	75 AS 5
Round hood 1-7535-6	75 AS 6
Flat hood 1-753324-6	75 AS 7

Brackets

Table bracket 2-7510-050	75 AS 8
Wall bracket 2-195-050	75 AS 9
Ceiling columns	75 AS 10

Accessories

Reducer 4-8075-6	75 AS 11
Reducer 4-10075-6	75 AS 12
Cover flange 4-200-200	75 AS 13
Support bracket 2-75-5	75 AS 14
Protective netting 5-17-6	75 AS 15



System 75 - Antistatic (AS)

All components RoHS-compatible.

Design:

- Extraction arm for mounting on table
- Working range 550 - 1290 mm
- Recommended airflow 80 to 180 m³/h
- Diameter of tube Ø75 mm
- Tubes and joints made of conductive, shatterproof, chemical resistant polypropylene (PP)
- All O-rings conductive and maintenance free
- Integrated valve. When in an open position out of the flow path to maintain the maximum amount of flow
- All threaded stays, springs and thumbscrews made of acid-proof stainless steel (AISI 316L)
- All rivets made of conductive chemical resistant polypropylene (PP) for increased durability in aggressive environments
- All hoods can be provided with a protective netting (accessory) to reduce the risk of extracting foreign objects
- Approved for ESD-areas according to IEC 61340-5-1:2016
- Approved for ESD/Ex-areas according to EN 80079-36:2016 and EN 80079-37:2016 according to ATEX directive 2014/34/EU labelled Ex II 1 GD
- The extraction arms are equipped with an earth wire for EX-areas.
For mounting in ESD-areas, an earth wire with a 1 MΩ resistance is enclosed
- Dismantling of the arm without tools for cleaning



Links: [Pressure drop chart](#), [Mounting](#), [User's manual](#), [Capture efficiency](#), [Test reports](#), [Material compatibility](#)

Working area

We do not recommend a stationary working position in the upper or lower working area.

All units in mm

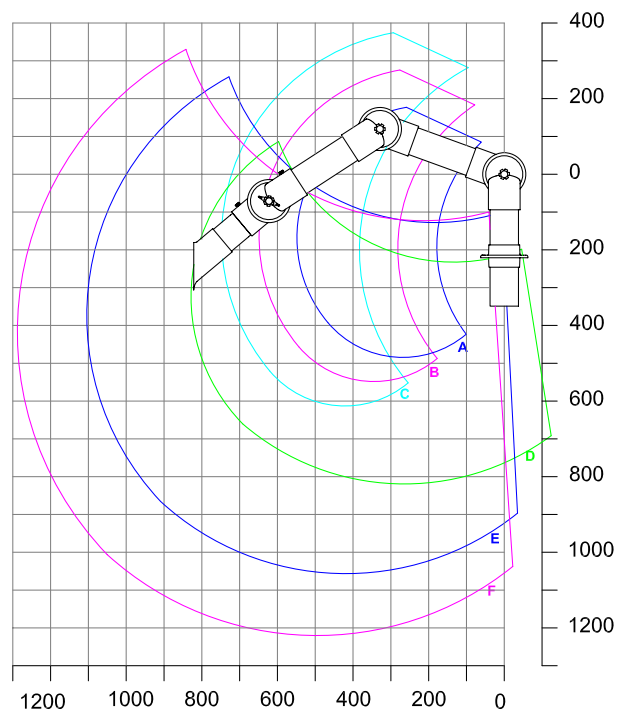

A: Model 75-35-1-6
B: Model 75-45-1-6
C: Model 75-55-1-6
D: Model 75-3535-1-6
E: Model 75-5545-1-6
F: Model 75-6555-1-6



System 75 - Antistatic (AS)

All components RoHS-compatible.

Design:

- Extraction arm for mounting on wall/ceiling
- Working range 550 - 1990 mm
- Recommended airflow 80 to 180 m³/h
- Diameter of tube Ø75 mm
- Tubes and joints made of conductive, shatterproof, chemical resistant polypropylene (PP)
- All O-rings conductive and maintenance free
- Integrated valve. When in an open position out of the flow path to maintain the maximum amount of flow
- All threaded stays, springs and thumbscrews made of acid-proof stainless steel (AISI 316L)
- All rivets made of conductive chemical resistant polypropylene (PP) for increased durability in aggressive environments
- All hoods can be provided with a protective netting (accessory) to reduce the risk of extracting foreign objects
- Approved for ESD-areas according to IEC 61340-5-1:2016
- Approved for ESD/Ex-areas according to EN 80079-36:2016 and EN 80079-37:2016 according to ATEX directive 2014/34/EU labelled Ex II 1 GD
- The extraction arms are equipped with an earth wire for EX-areas.
For mounting in ESD-areas, an earth wire with a 1 MΩ resistance is enclosed
- Dismantling of the arm without tools for cleaning



Links: [Pressure drop chart](#), [Mounting EX without gas spring](#), [Mounting EX with gas springs](#), [Mounting ESD without gas spring](#), [Capture efficiency](#), [Mounting ESD with gas springs](#), [User's manual](#), [Test reports](#), [Material compatibility](#)

Working area

We do not recommend a stationary working position in the upper or lower working area.

All units in mm

* With 1 gas spring

** With 2 gas springs

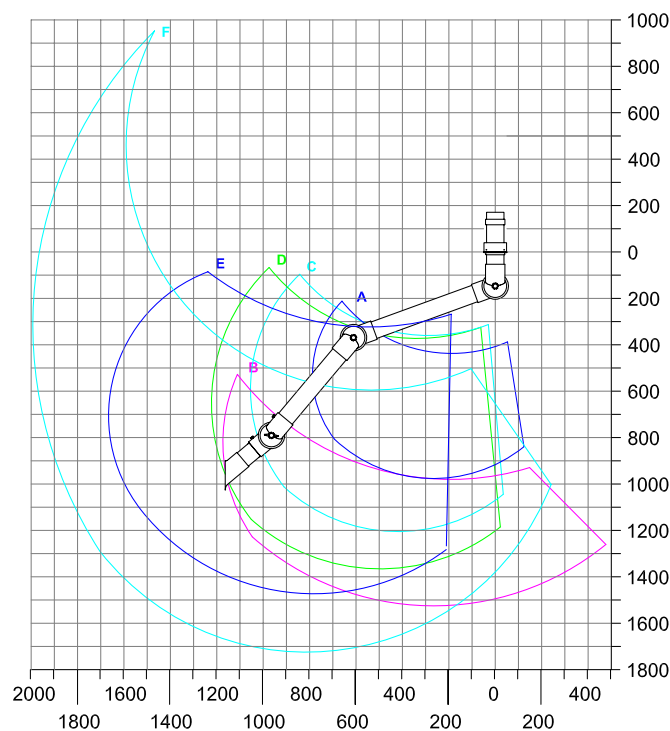

A: Model 75-3535-3-6
 B: Model 75-3590-3-6
 C: Model 75-5545-3-6
 D: Model 75-6555-3-6
 E: Model 75-9065-3-22-6*
 F: Model 75-9090-3-22-6**



System 75 - Antistatic (AS)

- Suction pen recommended for concentrated sources of pollution
- High efficiency as the suction pen gets close to the source without obstructing the work process
- Made of conductive, chemical resistant polypropylene (PP)
- With funnel in order to increase the capture efficiency
- Length: 250 mm

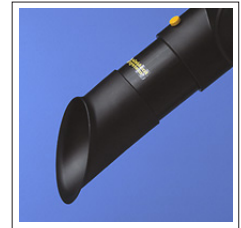

Capture efficiency

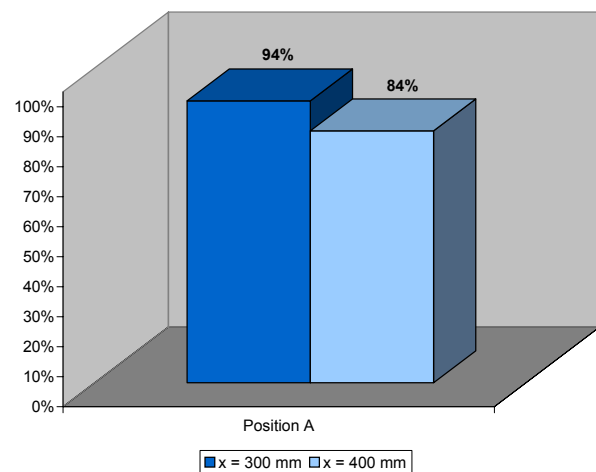
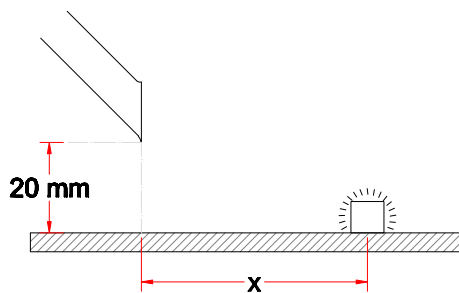

Drawing

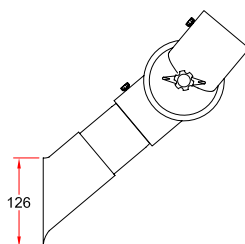



System 75 - Antistatic (AS)

- Metal hood recommended when extracting hot gases, fumes, light dust concentrations etc.
- Diameter of hood: $\varnothing 200$ mm
- Hood made of chromated (TCP) Aluminium to assure permanent conductivity
- Connecting tube and flange made of conductive, chemical resistant polypropylene (PP)



Capture efficiency

The relatively low efficiency indicates, that the illustrated position is not optimal for this hood. For system 100 other measurements have been made for a similar round hood - see article no. [1-10024](#).

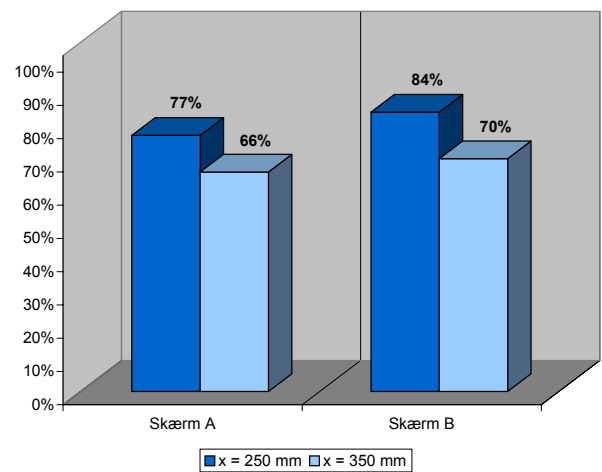
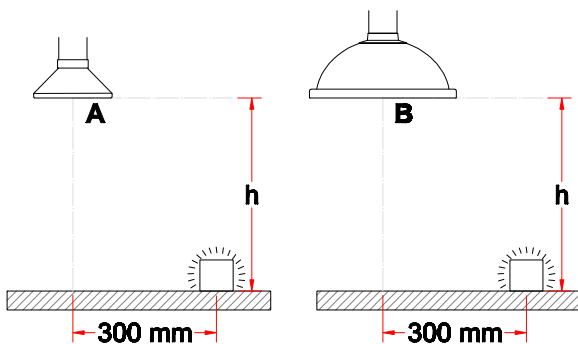

Drawing

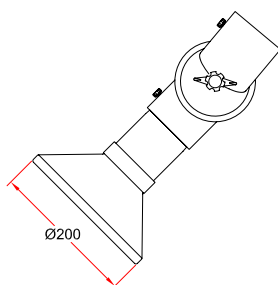



System 75 - Antistatic (AS)

- Round hood recommended for light fumes, gases and over small open vessels
- Diameter of hood: $\text{Ø}385$ mm
- Increased stability when moving the hood due to reinforced rim of the hood
- Increased efficiency at an angled position
- Hood, connection tube and flange made of conductive, chemical resistant polypropylene (PP)



Capture efficiency

The relatively low efficiency indicates, that the illustrated position is not optimal for this hood. For system 100 other measurements have been made for a similar round hood - see article no. [1-10050](#).

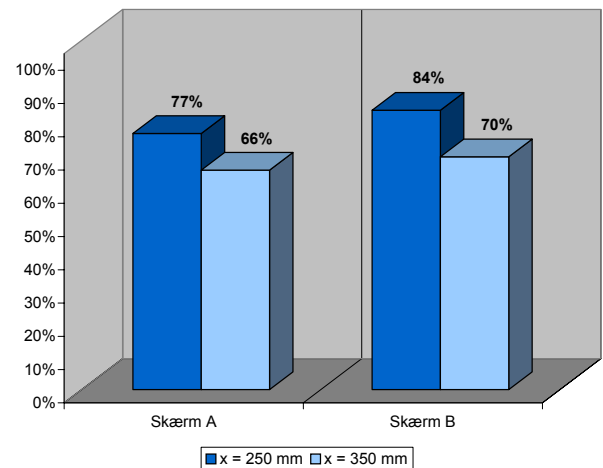
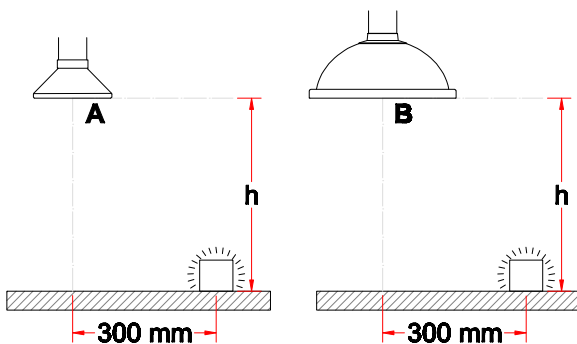

Drawing

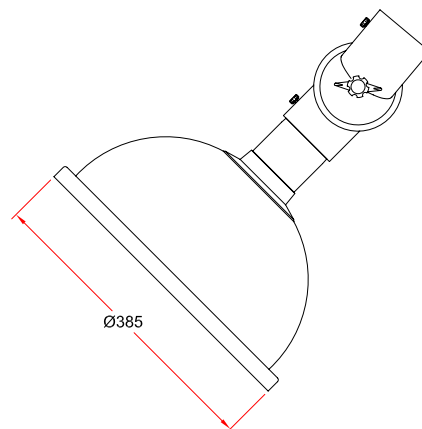



System 75 - Antistatic (AS)

- Flat hood recommended when extracting heavy gases and fumes
- Dimension of the hood: 330x240 mm
- Increased efficiency when placed vertically on a surface
- Hood, connection tube and flange made of conductive, chemical resistant polypropylene (PP)



Capture efficiency

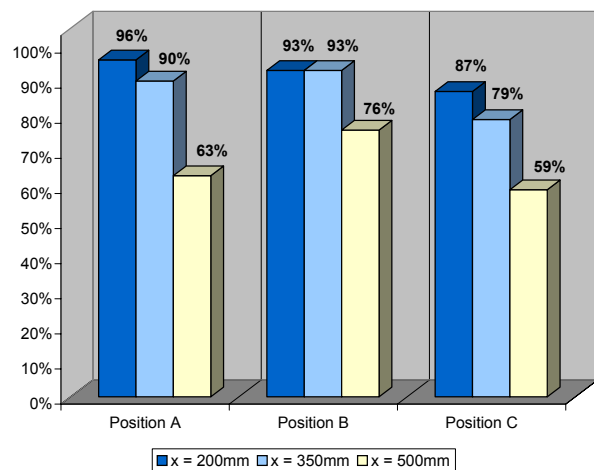
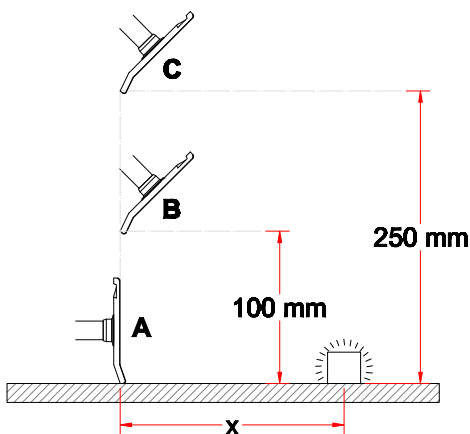

Drawing

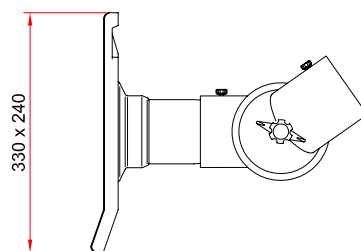

Table bracket 2-7510-050



System 75 - Antistatic (AS)

- Table bracket to mount extraction arms for table mounting at the edge of the table
- Easily removable without tools for mobile installations
- Made of steel with a polyester powder-coating on all surfaces
- Colour: black



Drawing

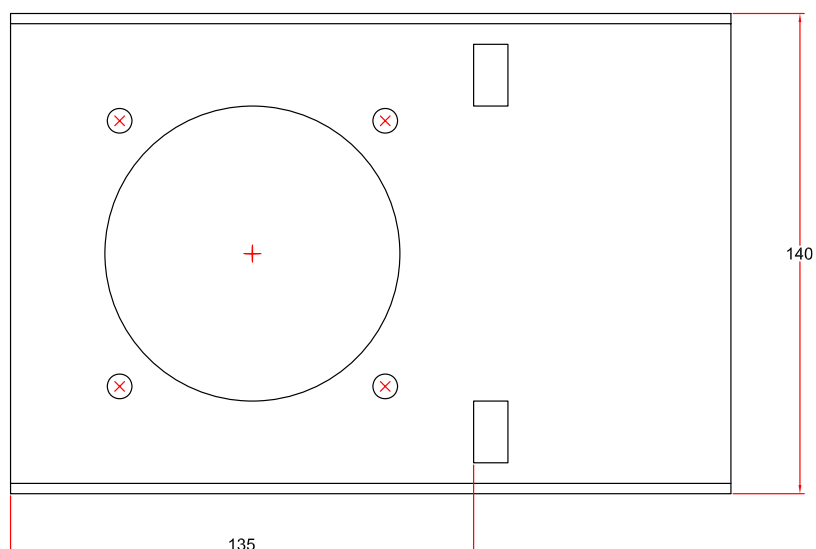
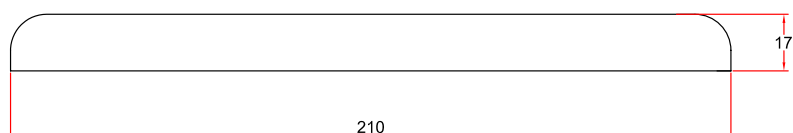



System 75 - Antistatic (AS)

- Bracket to mount extraction arms for wall mounting to the wall
- Made of steel with a polyester powder-coating on all surfaces
- Connection to ventilation duct:
 - Direct connection with a duct Ø80 mm
 - Connection with reducer 4-10075 to Ø100 duct
 - Connection with our Ø75 aluminium pipe in the length needed, when a stylish installation is required
- Colour: black



- ② Also available with closed sides for areas with special requirements of cleaning.
Article no. 2-195-10-5

Drawing

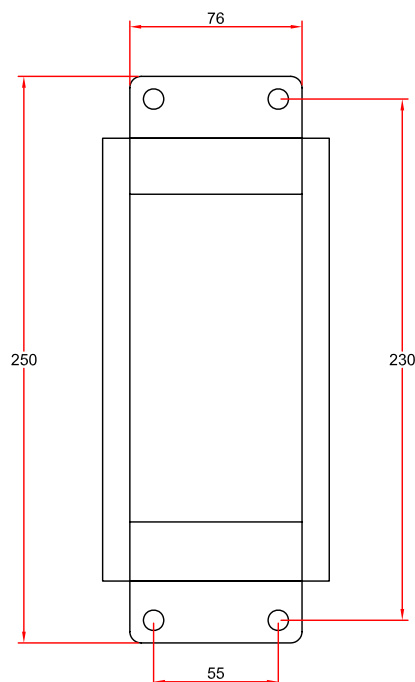
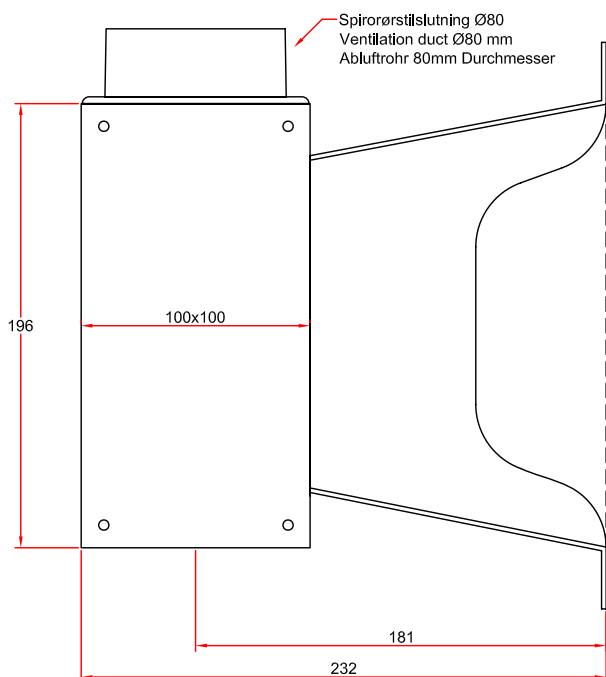



System 75 - Antistatic (AS)

- Ceiling columns to mount extraction arms for ceiling mounting to the ceiling
- Strong construction made of steel
- Increased durability due to polyester powder-coating on all surfaces
- Available with top connection (-20) or side connection Ø80 mm (-80)
- Colours available: white (-5) or black (-050)
- Dimension: 100x100 mm
- Lengths: 250 - 2500 mm



Drawing

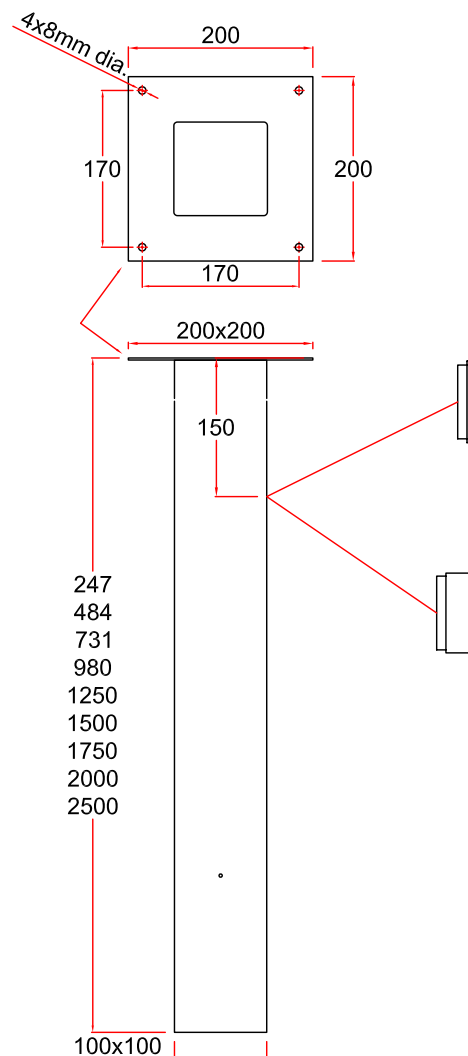



System 75 - Antistatic (AS)

- Reducer to connect extraction arm and ventilating duct
- Reduces from Ø80 - Ø75
- Made of conductive polypropylene (PP)
- Colour: Black



Drawing

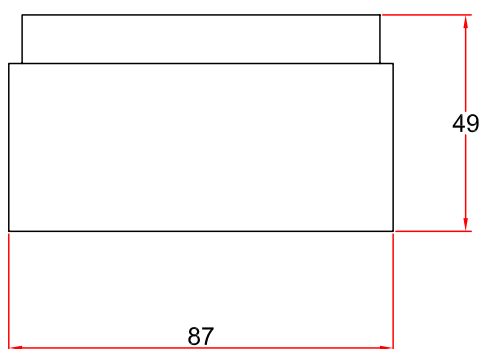



System 75 - Antistatic (AS)

- Reducer to connect extraction arm and ventilating duct
- Can be used to connect wall bracket to ventilating duct Ø100 mm
- Reduces from Ø100 - Ø75
- Made of conductive polypropylene (PP)
- Colour: Black



Drawing

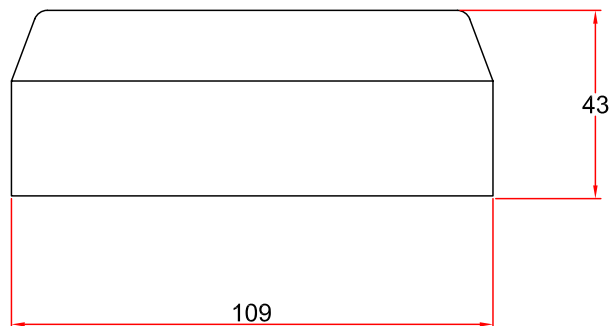



System 75 - Antistatic (AS)

- Cover flange to mount on false ceiling. Hides the carrying of the ceiling column through the false ceiling
- Fasten with glue or small screws
- Dimensions: 200 x 200 mm
- Material: polystyrene
- Colour: white

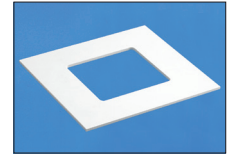

Drawing

For this product there is no drawing



System 75 - Antistatic (AS)

- For extra support of long ceiling columns when mounted to ceiling racks or with wires to the deck
- Made of steel with a polyester powder-coating on all surfaces
- Colour: white
- Dimensions: 200 x 200 mm



Drawing

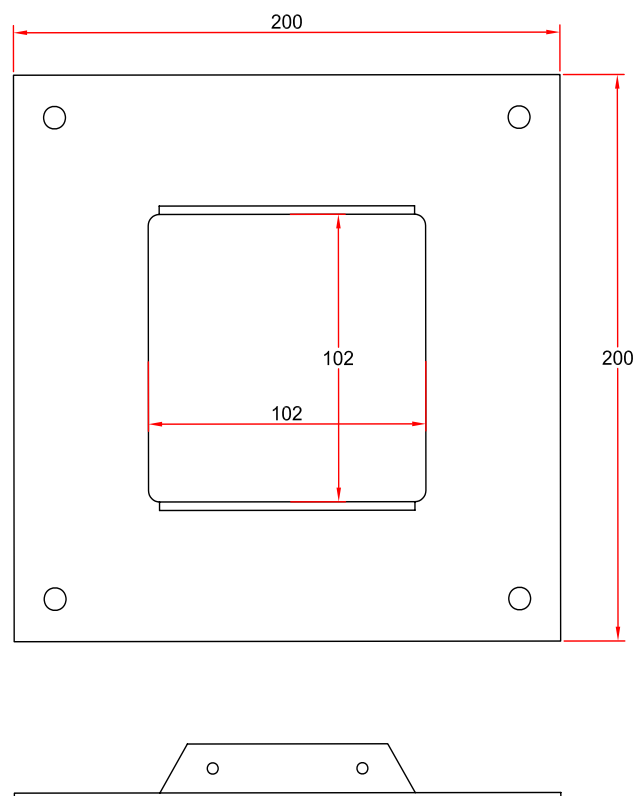



System 75 - Antistatic (AS)

- Protective netting to be placed in the hood
- Protects against extraction of foreign objects
- Conductive polypropylene (PP)
- Colour: Black



Drawing

